

Load Cell Technology

The heart of any weighing system is the load cell. While they are not exciting to watch, load cells are highly accurate transducers which provides the user with information not generally obtainable by other technology due to commercial factors.

Load cells are designed to sense force or weight under a wide range of adverse conditions; they are not only the most essential part of an electronic weighing system, but also the most vulnerable. In order to get the most benefit from the load cell, the user must have a thorough understanding of the technology, construction and operation of this unique device. In addition, it is imperative that the user selects the correct load cell for the application and provide the necessary care for the load cell during its lifetime. Understanding these important issues and properly maintaining the load cells will ensure trouble free weighing for a long period of time.

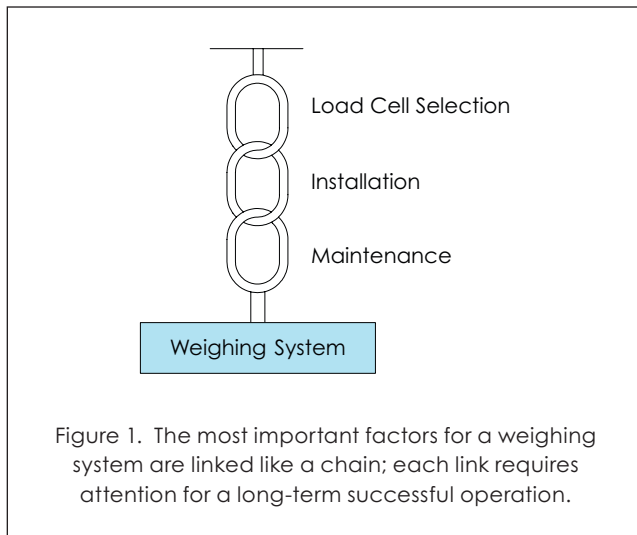

Figure 1. The most important factors for a weighing system are linked like a chain; each link requires attention for a long-term successful operation.

Load cells may be damaged because of (shock) overloading, lightning strikes or heavy surges in current, chemical or moisture ingress, mishandling (dropping, lifting on cable, etc.), vibration, seismic events or internal component malfunctioning. This article will focus on the Do's and Don'ts for load cells as well as on basic system design.

1. Load Cell Selection

Load cell selection in the context of trouble free operation concerns itself primarily with the right capacity, accuracy class and environmental protection, rather than with a particular measuring principle like bending, shear, compression or ring torsion. While saying this, it should also be recognized that a particular measuring principle might offer distinct advantages in terms of overload capabilities or the ease of mounting. The different principles of operation will therefor be discussed shortly.

1.1 Strain gage load cells

The sensing or spring element is the main structural component of the load cell. The element is designed in such a way that it develops a strain, directly proportional to the load applied. Sensing elements are normally made of high strength alloy steels (nickel plated for environmental protection), precipitation — hardened stainless steels, heat treated aluminium alloys, or beryllium copper alloys.

By bonding strain gages to a precisely machined element, the force applied can be identified in terms of resistance change. The strain gages, usually four or a multiple of four, are connected into a Wheatstone bridge configuration in order to convert the very small change in resistance into a usable electrical signal. Passive components such as resistors and temperature depending wires are used to compensate and calibrate the bridge output signal.

1.1.1 Bending load cells

Sensing elements which are subjected to bending moments are widely used, in many configurations, for commercial transducers. Bending beams offer high strain levels at relatively low forces, which makes them ideal for low capacity load cells.

Furthermore, in case of a beam with a symmetrical cross-section about the bending axis, there are always two surfaces subjected to equal strains of opposite sign. This offers convenient means for implementing a full bridge circuit, while temperature compensation is relatively easy.

Load Cell Technology

Most products using the bending principle are of the parallelogram or double bending type.

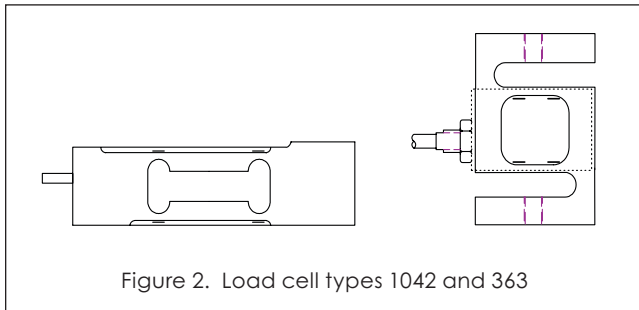

Figure 2. Load cell types 1042 and 363

Bending as a measuring principle offers excellent linearity. Bending beams have relatively high strain levels with greater deflection compared to other measuring principles. This in turn means that although the cell is subjected to greater static overload, mechanical stops are more feasible. The dynamic overload capabilities are excellent because of the typical high deflection.

1.1.2 Shear load cells

Shear (beam) load cells have become increasingly popular for all types of medium and high capacity applications. Shear as a measuring principle offers a standard profile for a given capacity, good resistance against side loads and a relatively small sensitivity to the point of loading.

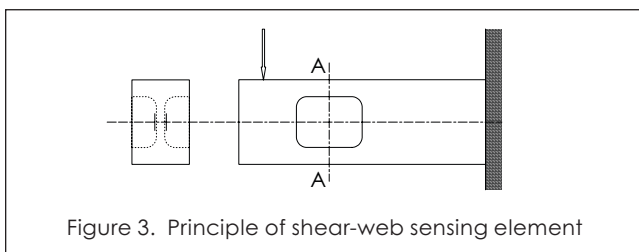

Figure 3. Principle of shear-web sensing element

At section A-A of the beam, a recess has been machined in each side, leaving a relatively thin web in the center. Just as in a structural I-beam, most of the shear force imposed by the load is carried by the web, while the bending moment is resisted primarily by the flanges. At the neutral axis, where the bending stress is negligible, the state of stress on the web is one of pure shear, acting in the vertical and horizontal directions. As a result, the principle axes are at $\pm 45^\circ$ to the longitudinal axis of the beam, and the corresponding principal strains are of equal magnitude and opposite sign. Pairs of strain gages are installed on both sides of the web and connected in a full-bridge circuit for load measurement. Although it

is more difficult to install the strain gages in some form of recess, they can readily be sealed and protected against environmental effects.

Low capacity shear load cells are difficult to produce, because they require a very thin web to obtain the necessary strain levels. High capacity shear load cells are usual based on dual shear webs in a beam configuration, as single ended beams become expensive and cumbersome to mount. Shear beam load cells are relatively insensitive to the point of loading and offer a good resistance to side loads. This simplifies its use in many weighing applications. The overload capabilities are usual slightly better compared to bending beams, although mechanical stops are less feasible because of minimal deflection.

1.1.3 Compression load cells

Compression load cells can be based on shear, bending, ring torsion or column measurement. The column load cell has a history which dates back to the earliest strain gage transducer. As indicated below, the column element consists of one (single column) or more (multiple column) members.

Although conceptually simple, the column element has a number of specific characteristics which makes these load cell types difficult to design and produce. The column itself should be long enough, with respect to its cross section, to provide a uniform strain field, unaffected by end conditions. Since the column configuration is subject to second-order effects from off-axis or off-center load components, provisions must be made to minimize these, for example by using two diaphragms at the upper end of the column.

Column load cells are inherently non-linear due to the change in cross section, while deforming under load (Poisson's ratio). This non-linearity can be compensated for with semi-conductor gages, connected in the

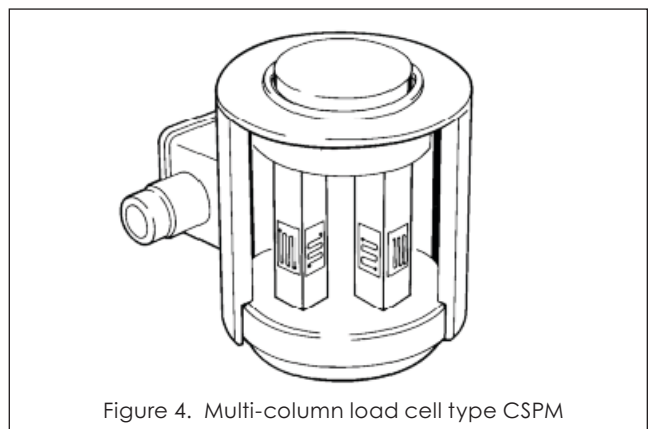

Figure 4. Multi-column load cell type CSPM

Load Cell Technology

plus and minus excitation lines. The output of the semiconductor gage thus serves as a feedback for adjusting the bridge voltage in the opposite direction to that of the non-linearity error.

Single column load cells become tall and difficult to handle (heavy), when designed for very high loads. Low profile canisters can be obtained if the load is carried by three or more columns, each column with its own set of gages. The corresponding gages from all of the columns are connected in series in the appropriate Wheatstone bridge arms. *The result is not only an overall low profile, but also an improved performance when the cell is off-center or off-axis loaded.*

Compression type load cells don't suffer from the momentum typically associated with beams. The ultimate overload capabilities are therefore excellent. However, the relatively small deflection makes these load cell types more sensitive to shock loading.

1.1.4 Ring torsion load cells

The ring torsion measuring principle is relatively new, and ideally suited for the capacity ranges which are typically served by shear and bending beams. VPG Transducers load cell model RLC is a low profile, stainless steel ring torsion load cell, based on a full bridge circuit of four circular strain gages. The strain gages are bonded to a ring-shaped part of the element which will bend when load is introduced. This process will cause a decrease of the ring diameter at the top, while the bottom experiences a diameter increase. Hence, two gages are compressed and two gages are in tension, when the unit is loaded.

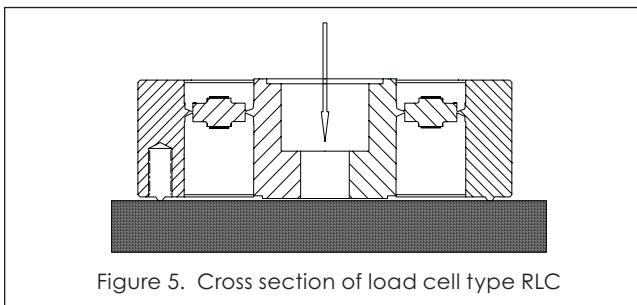

Figure 5. Cross section of load cell type RLC

The geometrical design of the sensing element provides enhanced specifications in terms of creep and hysteresis compared to shear and bending as a measuring principle.

Due to its compression loading mode, the unit does not suffer from the momentum typically associated with beams, and is therefore an inherently safer

device, while maintaining an extremely low profile. Mechanical overload protection is established by the pre-determined distance between the load introduction ring and the base plate. Ring torsion load cells have a very low deflection, which makes them ideal for high speed weighing, but they are also more sensitive to shock overloading.

1.2 Capacity Selection

Overload is still the primary reason for load cell failure, although the process of selecting the right load cell capacity looks easy and straight forward on first sight. Capacity selection requires a fundamental understanding of the load related terms for load cells as well as the load related factors associated with systems. The load related terms for load cells are:

Load cell measuring range:

The range of values of mass for which the result of measurement should not be affected by an error exceeding the maximum permissible error.

Safe load limit:

The maximum load that can be applied without producing a permanent shift in the performance characteristics beyond those specified as a percentage of the measuring range (i.e., 150%).

Ultimate overload:

The maximum load that can be applied without physical destruction of the load cell; specified as a percentage of the measuring range (i.e., 300%).

Safe side load:

The maximum load that can act 90° to the axis along which the load cell is designed to be loaded at the point of axial load application without producing a permanent shift in the performance beyond those specified as a percentage of the measuring range (i.e., 100%).

Summary:

A load cell will perform within specifications until the safe load limit or safe side load limit is passed. Beyond this point, even for a very short period of time, the load cell will be permanently damaged. The load cell may physically break at the ultimate load limit.

The factors that contribute to the weight load on the load cells are: zero tracking, initial zero setting, dead load, maximum scale capacity, location, and specific factors like wind forces or seismic events.

Load Cell Technology

In addition to these, it is often necessary to derate the load cells (use a higher capacity) because of:

- Shock loading
- Dynamic influences (agitators)
- Off center loading to the scale
- Off center distribution of dead load
- The possibility of an overload weight

The difference between normal or static overload and shock overload is often misunderstood and needs further explanation. Static overload is defined as a gradual increase in weight over and above the rated capacity of the load cell.

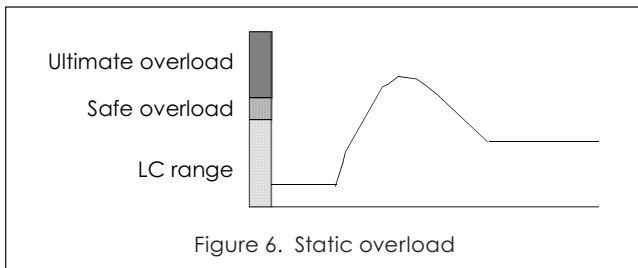

Figure 6. Static overload

Systems can be protected by incorporating mechanical stops, or by selecting load cells with a higher rated capacity.

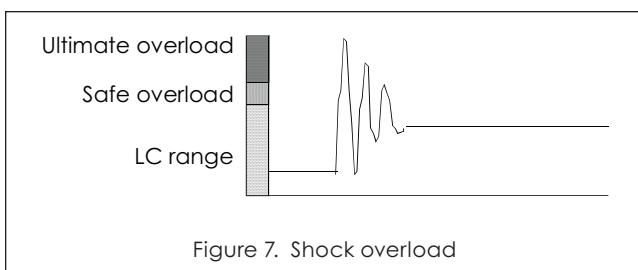

Figure 7. Shock overload

Shock overload can be defined as a sudden change in weight, within a very short period of time, over and above the rated capacity of the load cell. This situation specifically occurs when a relatively small non-elastic item is dropped from a considerable height on the scale. Systems can be protected by incorporating shock insulation pads, or by selecting load cells with a higher rated capacity. Mechanical stops act to assist the protection against shocks.

Particular care must be given to load cells with a low deflection, as they are more sensitive to dynamic overload.

Both types of overload result in a sudden change of zero balance, the temperature compensation on zero is also affected.

The following calculations and table should be used to calculate the correct load cell capacity:

$$LC_{cap} = [\text{Dead load} + (\text{Live load} * F_d)] / N + F_t + F_w$$

where:

N = Number of load cells

F_a = Dynamic load factor

F_w = Effect of wind force (for hoppers)

F_t = Combined effect of zero setting devices:

$$F_t = [\text{Live load} * \text{Zero setting devices} (\%) / N * 100$$

	F_a	De-Rate*
Platform scale	1.4	30 → 50%
Weighbridge	1.4	30 → 50%
Single cell application	1.3	20 → 40%
Single cell hybrid bridge	1.2	10 → 30%
Hopper, equal load distribution	1.1	10 → 30%
Hopper, unequal load distribution	1.2	20 → 40%
Hopper, with agitator	1.3	20 → 40%

* Determine the value based on the load cell's measuring principle (low deflection & value high).

For example:

A platform scale with a capacity of 1500 kg is built with four load cells. The scale has an initial zero setting of 16% and a zero tracking of 4%. The dead load equals 100 kg. The load cell capacity should be:

$$F_t = [1500 * (16 * 4)] / 4 * 100 = 75$$

$$LC_{cap} = [100 + (1500 * 4) / 4] + 75 + 0 = 625 \text{ kg}$$

Depending on the load cell's measuring principle, the required load cell capacity varies between 895 and 1250 kg (derate 30 to 50%).

It is important to verify the output per scale division with the required minimum signal level for the measuring device to ensure compatibility. The output per division (in μV) can be calculated by:

$$(U_E * S * \text{Live load} * 1000) / N * LC_{cap} * n$$

where:

U_E = Excitation voltage

S = Rated output load cell

n = Number of scale divisions

Load Cell Technology

For example:

The above scale configuration is built with 4 load cells, output 2 mV/V, 3000 divisions, rated capacity 1000 kg and an excitation voltage of 10 V. The output per division will be:

$$(10 * 2 * 1500 * 1000) / 4 * 1000 * 3000 = 2.5 \mu V$$

1.3 Accuracy

Load cells are ranked, according to their overall performance capabilities into differing accuracy classes. Some of these accuracy classes are related to standards which are used in legal for trade weighing instruments, while other accuracy classes are defined by the individual load cell manufacturer.

Depending on the standard and the performance of a particular load cell type, an alphanumeric "accuracy grade" is given to the product. The alpha designate refers to the specific accuracy class, while the numeric part refers to the number of divisions.

VPG Transducers manufactures products meeting NTEP, OIML and in-house specifications. These product are designated:

- Az Products meet the NTEP requirements for class III applications.
- Bz Products meet the NTEP requirements for class III L applications.
- Cz Products meet the OIML requirements for class III and III L applications.

Note "z" represents the number of divisions (x1000), i.e., A3, B10, C6, etc.

Most weighing systems use load cells where their working or measuring range is well below their rated capacity. In these situations, the values for the load cell utilization and minimum verification interval (v_{min}) are important.

The minimum verification interval is defined as the smallest value of a quantity (mass) which may be applied to a load cell without exceeding the maximum permissible error. It is specified as E_{max} / γ , where E_{max} represents the load cell's rated capacity and γ represents a value which is specified by the load cell supplier.

The minimum measuring range can apply over any part of the measuring range between the minimum dead load (E_{min}) and the rated capacity (E_{max}).

A load cell may be used over a working range larger that its minimum utilization.

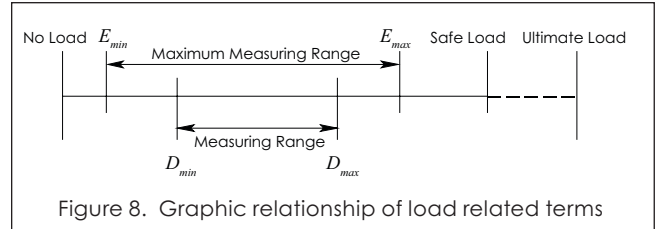

Figure 8. Graphic relationship of load related terms

The terms above the central horizontal line are fixed by the design of the load cell, while the terms below are fixed on the conditions of use and cell performance.

1.3.1 Approved systems

Legal for trade weighing systems require load cells which are certified according to the National Type Evaluation Program (NTEP) or OIML recommendation R60 (Europe). The requirements in terms of load cell accuracy for the above mentioned systems are:

- 1) Select a cell which is certified according to the appropriate standard, i.e., products designated "Az" for class III applications.
- 2) For each load cell, the maximum number of load cell intervals shall not be less than the number of verification scale intervals. For example; a 3000 division class III scale requires A3 load cells.
- 3) The minimum load cell verification interval shall satisfy the condition:

$$v_{min} \leq e * R / \sqrt{N}$$

where e represents the scale verification interval and R represents the reduction ratio of the load transmitting device (hybrid scales).

$$R = \frac{\text{Load acting on the load cell(s)}}{\text{Load acting on the receptor (scale)}}$$

For example:

A fully electronic scale (R=1), with four load cells and a measuring range of 6 t divided into 3000 divisions requires load cells with the following v_{min} :

$$v_{min} \leq \frac{6000 * 1}{3000 \sqrt{4}} \Rightarrow v_{min} \leq 1 \text{ kg}$$

1.3.2 Non-approved systems

The load cell selection for non-approved weighing systems can be based on the specified error percentages which are indicated on our datasheets.

Load Cell Technology

1.4 Environmental Protection

No area of load cell operation causes more confusion and contention than that of environmental protection and sealing standards. Although our industries have in-depth standards and test procedures to define load cell and weighing system performance, no standards have been developed to cover product suitability for specific environmental conditions.

In the absence of such standards, most manufacturers have adopted the International Protection system (IP/IEC 529 or EN 40.050) or National Electrical Manufacturers Association Standards (NEMA publication 250). Define the level of sealing for their products. Both standards are good test procedures for environmental sealing when applied to the products for which they were intended — those being electrical enclosures, but they are not very well suited to load cells.

1.4.1 IP Classification

The IP standard describes a system for classifying the degree of protection provided by the enclosures of electrical equipment:

- Protection of persons against access to hazardous parts inside the enclosure.
- Protection of the equipment inside the enclosure against the ingress of solid foreign objects.
- Protection of equipment inside the enclosure against harmful effects due to the ingress of water.

Unfortunately, no definition is given for the term "harmful effects". Presumably, for enclosures, the main problem with water could be one of electrical shock to persons in contact with the enclosure, rather than malfunctioning of the unit. Furthermore, the standard only relates to water ingress and ignores moisture, chemicals, corrosion, etc.

The commonly used categories to describe load cell sealing are:

- IP65 Protected against low pressure jets of water from all directions, limited entrance allowed
- IP66 Protected against strong jets of water e.g., for use on ship decks, limited entrance allowed
- IP67 Protected against the effects of immersion between 15 cm and 1 m
- IP68 Protected against long periods of immersion under pressure

1.4.2 NEMA Classification

Classifications in the NEMA system run from NEMA 1 to NEMA 12, but load cell manufacturers concern

themselves with NEMA 4 and NEMA 6. Unlike the IP system, NEMA does concern itself with environmental conditions such as corrosion, rust, freezing, oil and coolants.

NEMA 4 enclosures are intended for indoor and outdoor use, providing a degree of protection against windblown dust, rain, splashing water, and hose directed water. However, no consideration is given for the effects of internal condensation. Nema 4X enclosures meet the same standards as NEMA 4 and are constructed of 304 stainless steel or other material offering equal corrosion resistance.

NEMA 6 enclosures are used where there is a chance of temporary immersion. This standard calls for the highest part of the enclosure to remain submerged in water, with its highest point 1.83 metres below the surface for 30 minutes. NEMA 6P enclosures are used where prolonged immersion may occur and resistance to corrosion is needed.

While it may seem that NEMA standards offer some advantages over the IP system for corrosion resistance, they only relate to external corrosion of enclosures. This is very limited when applied to the more complex load cell construction and the different effects of corrosion or water ingress.

1.4.3 Damp Heat Cycling (IEC 68-2-30)

The IP and NEMA standards don't deal with internal condensation or moisture within the enclosure. However, moisture or condensation is of vital importance in correct load cell operation.

Moisture may enter the inside of the load cell over a long period and have a catastrophic effect, especially when acids or alkalis are present. One test used to determine a load cell's ability to withstand moisture or condensation is the Damp Heat Cycling Test.

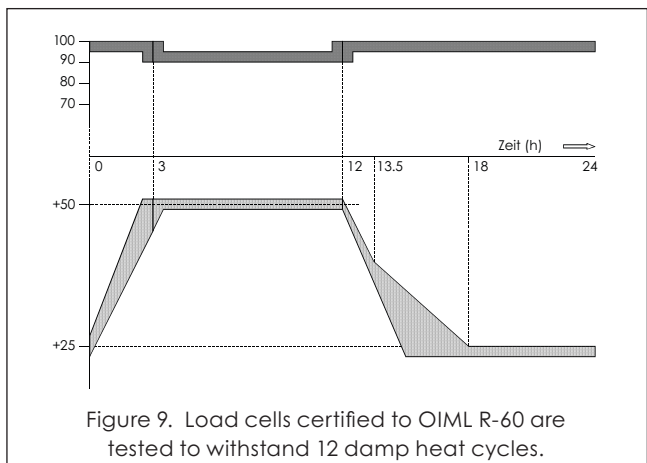

Load Cell Technology

The object of the IEC standard is "To determine the suitability of components, equipment, or other articles for use and storage under conditions of high humidity when combined with cyclical temperature changes".

It is obvious that this standard is a much more useful classification than the IP or NEMA rating when it comes to defining load cell environmental suitability.

1.4.4 Load cell construction

Besides a given IP-rating or NEMA-classification load cells should also be classified according to their design in terms of cable entry, material of construction and gages sealing method.

While it is relatively common to weld-seal critical areas on a load cell body, one potential problem area is the cable entry. A variety of methods are used to make sure cells are properly sealed at this area.

In most load cells the main cable enters through a conventional cable gland directly into the gage area. Regardless of how well the gage area is sealed, moisture and solvents can penetrate either around the gland or through the center of the cable itself. Often, temperature changes cause a pumping action to occur, pushing moisture down the inside of the cable. Entry also can be via a leaking junction box or through a damaged part of the cable. This can take some time to reach critical areas, but once there it will become sealed in place and do critical damage.

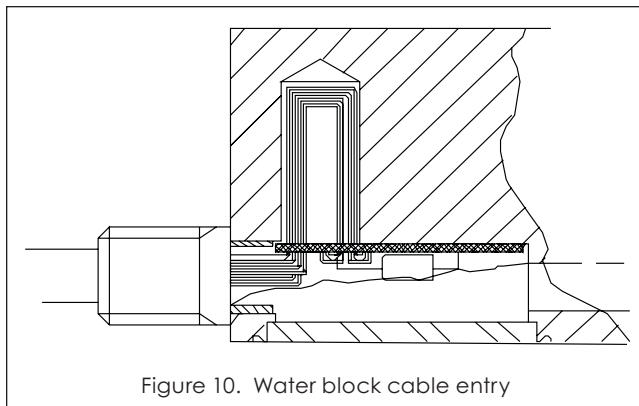

Figure 10. Water block cable entry

An improvement on the basic cable gland is a water block at the point of cable entry. Here, the main cable terminates at for example a small circuit board with on-going wires leading to the gage area. The block is fully potted to prevent moisture or other contaminants from reaching the critical areas.

The best solution is the use of a glass-to-metal cable entrance. This prevents any contamination from reaching the gage or other critical areas. In addition, the manufacturing process used must keep the load cell free from residue contaminations.

1.4.5 Corrosion

The corrosion resistance of load cells is a very complex subject, one that is further complicated by the variety of available configurations. As a result it is only possible to use standard corrosion charts as a guidance for load cells. In addition, the following factors must be considered:

- Surface finish
- Weld areas around seals, bellows and cups
- Thickness of seals
- Varying construction materials
- High stress levels at loading points
- Cable material (PVC, PUR or Teflon®)

The environment itself plays an important role in how a particular load cell type behaves in practice. Salt water, for example, has different corrosion effects depending on the local circumstances. Stainless steel in stagnant salt water is subject to crevice corrosion and a regular wash down is necessary to avoid degradation.

Unfortunately the term stainless steel has become synonymous with "no corrosion, no problem and no maintenance". While stainless steel load cells usually offer optimum protection in most environments, other factors should be taken into account. In certain applications, painted or plated load cells may offer better long-term protection.

An alternative is wrap-around protective covers. These can provide good environmental protection, but can be self-destructive if corrosive material is trapped inside the cover.

1.5 Summary

Selecting the wrong load cell for an application in terms of environmental compatibility can have far reaching consequences in terms of costs, safety and product reputation. Current classifications fall well short of defining adequate environmental standards for load cells.

Teflon is a registered trademark of DuPont.

Load Cell Technology

The users should compare like-for-like features when selecting products from different manufacturers. If in doubt, they should ask pertinent questions relating to:

- Construction of the load cell
- Cable entry method
- Past experiences

For applications in harsh environments, additional protection for the load cells may be needed to assure their reasonable working life. This can be achieved with enhanced scale designs and the use of additional coatings on the load cell, such as paints, greases and plating. The scale or system design should minimize the possibility of material build-up around the cells. If appropriate, the design should also provide mechanical protection from the effects of direct water and solvents while cleaning. Sealing compounds and rubbers used on some load cells can deteriorate when exposed to chemicals or direct sunlight. Because they embrittle rubber, chlorine-based compounds are a particular problem.

2. Installation

The installation of load cells into a practical field application requires careful attention if the system is to be safe and accurate.

It is a common misconception that a load cell can be considered as a solid piece of metal on which hoppers or platforms can be supported. The performance of a load cell depends primarily on its ability to deflect repeatedly under conditions when load is applied or removed. Furthermore, if more than one load cell is used then the deflection and output of each individual cell should be similar on each load point.

To satisfy the above requirements, load cells are mainly used in conjunction with special mounting systems rather than being mounted rigidly between platform/hopper and foundation. Load cell supports should be designed to avoid the following effects to the load cell:

- Lateral forces
- Bending moments
- Torsion moments
- Off center loading to the cell
- Vibration to the load cell

These effects not only compromise the performance of the load cell, but they can also lead to permanent damage.

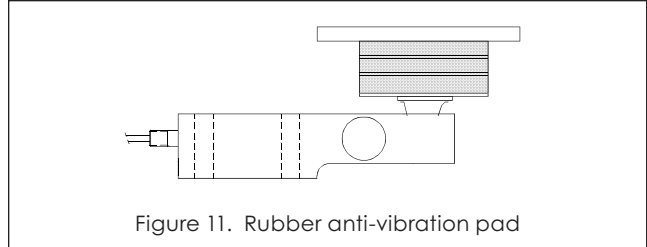

Figure 11. Rubber anti-vibration pad

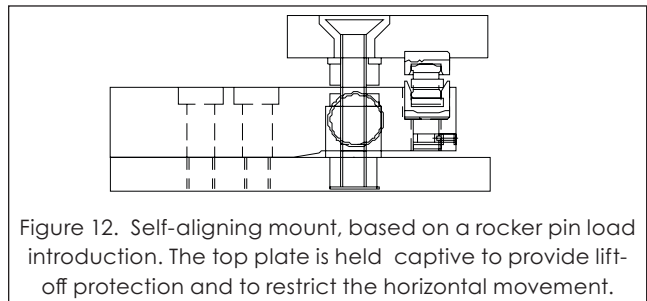

Figure 12. Self-aligning mount, based on a rocker pin load introduction. The top plate is held captive to provide lift-off protection and to restrict the horizontal movement.

If major load movement is anticipated, stay rods should be used to restrain a platform (weighbridge) or vessel. Stay rods are installed horizontally and should not transfer any forces to the vessel or scale in the vertical direction, while having sufficient strength in the horizontal direction to be able to absorb side forces. The length of the rods should be chosen as long as possible, as this has a favorable effect on reducing vertical forces.

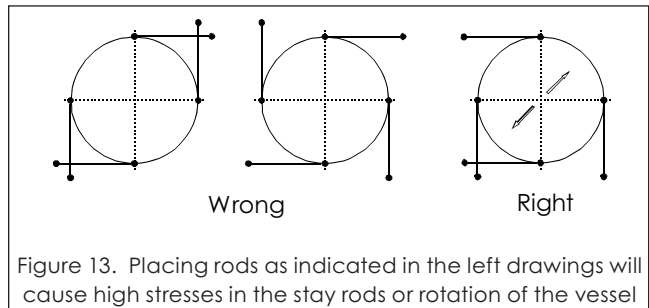

Figure 13. Placing rods as indicated in the left drawings will cause high stresses in the stay rods or rotation of the vessel

The arrangement of the stay rods depends on the plan view geometry of the structure. In most cases four rods give the best results.

Stay rods provide stability and accuracy, specially for systems with agitators. They should be installed carefully (exactly horizontal) and without any stress. Stay rods should not be confused with safety rods, which are installed similar, but provide a different function. Safety rods are left loose during normal operation. They are an extra safety feature in the event of wind forces, seismic activity or mechanical failure of mounts or load cells.

Load Cell Technology

Safety rods are strongly recommended for those systems where one of the above events could seriously affect personnel safety or where one of the above events could lead to extensive damage.

In order to assure performance, load cells should be placed on exactly the same horizontal level. Never use mounting bolts to pull uneven surfaces together; shim plates should be used as appropriate.

The preferred orientation of the load cell depends primarily on its design. The load should always be transmitted vertically through the load cell in the way which it was designed to measure force.

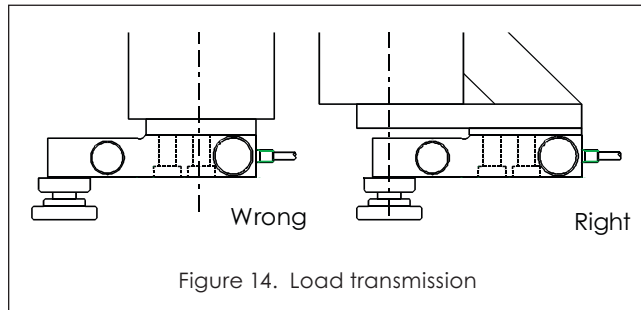

Figure 14. Load transmission

S-type load cells should be mounted in such a way that side forces are reduced to a minimum; they should never be mounted rigidly (even only at one side) between the structure and hopper. The load cell must be orientated in such a way that the cable entry does not affect weighing accuracy.

In terms of safety, attention should be paid to use the full length of thread, while considerations should be made to provide an external back up system.

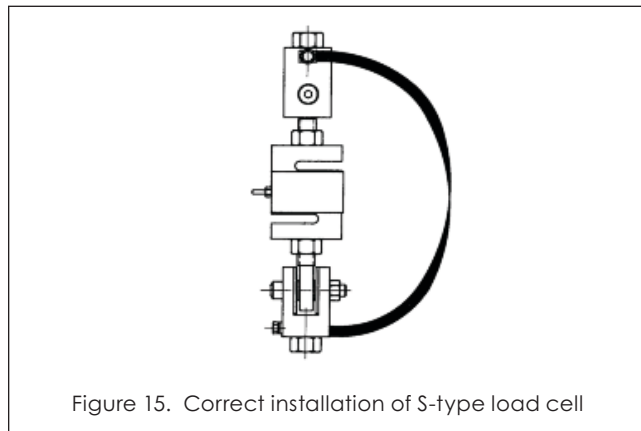

Figure 15. Correct installation of S-type load cell

To prevent load cells from being damaged during installation, it is strongly recommended to use dummies or mounting assemblies that can be "locked". Load

cells should be handled with care, especially those with a low rated capacity or with metal bellows construction.

Single ended beam load cells are subjected to a momentum and require high quality bolts for safe operation. The amount of torque on these bolts is specified and should be met to achieve the maximum performance.

2.1 Load cell cables

Special attention should be paid in preventing the load cell cable from being damaged during and after installation. Never carry load cells at their cables and provide dripping loops to prevent water from running directly into the cable entry.

Load cells are produced with a four- or six-wire cable. A four-wire cable is calibrated and temperature compensated with a certain length of cable. The performance of the load cell, in terms of temperature stability, will be compromised if the cable is cut; **never cut a four-wire load cell cable!**

A six-wire load cell cable has two additional wires which can be used to actually measure the excitation voltage at the load cell in order to feed this information back to the indicator. A six-wire load cell is not part of the load cell's temperature compensating system and can be cut to any desired length. However, it should be recognized that the parallel connection of multiple six-wire load cells results in an equal potential difference over all cells. All load cell cables should therefore be shortened to the same length.

2.2 Junction boxes

The junction box is an essential part of the system and should be protected to at least IP65 or NEMA 4. Select the location of the junction box based on the environmental conditions; NOT on the ease of installation.

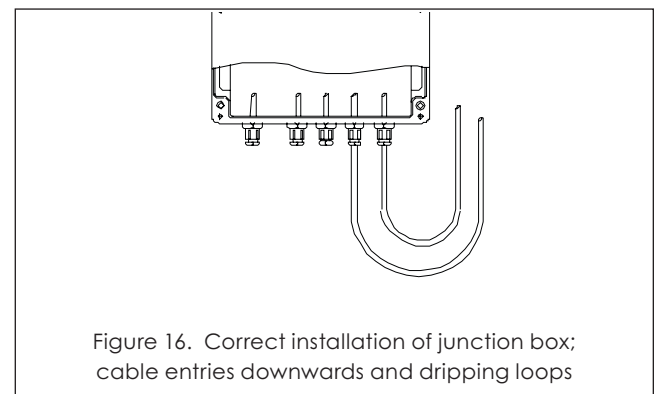

Figure 16. Correct installation of junction box; cable entries downwards and dripping loops

Load Cell Technology

During the installation ensure that no moisture enters the load cell cable before and during installation. A bag of drying agent (silica gel) may be enclosed to absorb moisture. However, the drying agent should never make contact with any non-insulated wiring in the box.

Use junction boxes with high quality terminals or use solder connections. The components used for corner correction should be absolutely temperature stable.

2.3 Welding

Avoid electric welding after installation of the load cells. If welding is necessary and the load cells can not be removed then disconnect each individual load cell cable from the junction box or measuring device.

Place the clamp earthing electrode of the welding apparatus in the close proximity of the weld to avoid a current path through the load cells. Furthermore, connect a flexible copper lead over each load cell.

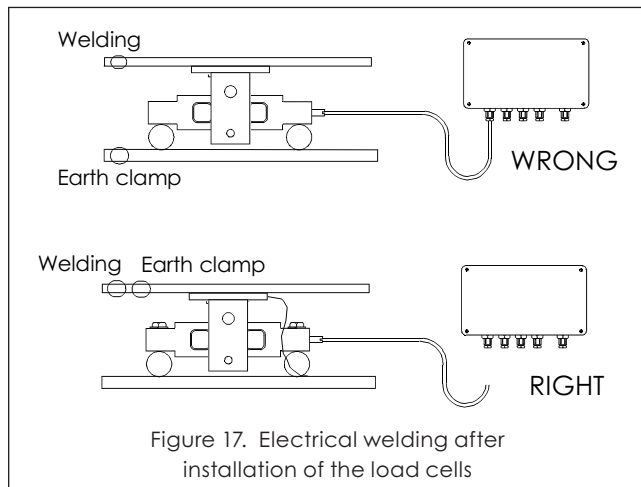

2.4 Lightning protection

Modern weighing systems rely heavily on high performance electronic components, but the features that make this possible also makes these components more vulnerable to the disruption and damage that can be caused by lightning or over-voltage in general.

Investigations indicate that a lightning strike within a 900 ft radius of the geometrical center of the site will definitely have a detrimental effect on the weighbridge. Nor is such damage confined only to earth strikes, since cloud-to-cloud strikes are equally capable of producing an electromagnetic pulse (EMP) of sufficient strength to cause damage.

In most cases, the actual load cell damage is a direct result of a potential difference, well in excess of 1000 volts, between circuit and housing.

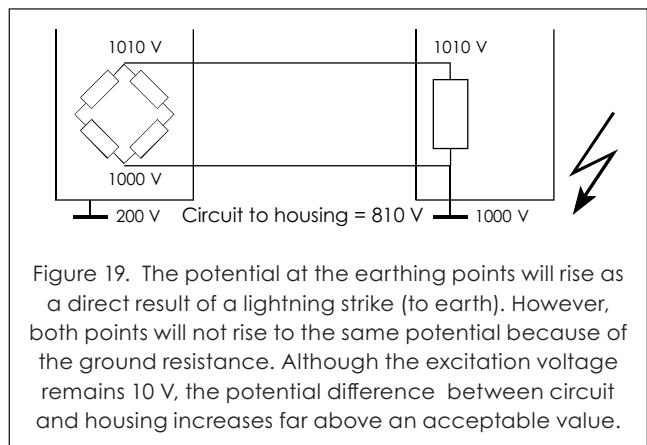
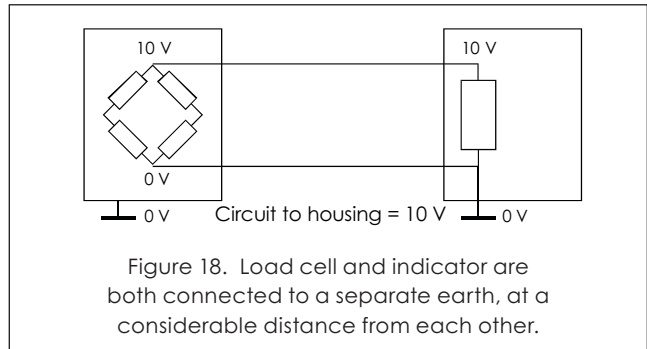

It should be recognized that a high potential difference between housing and load cell circuit can be caused by:

- A rise of local earth potential when a lightning strike is dissipated through the ground.
- Severe over-voltages or electromagnetic pulses via the main power supply.

The damage in both cases might result in a complete burn out of the component, but this is not always true. It is possible that only a part of the load cells circuit or one of the strain gage's glue layer is damaged. As a result the scale starts to drift and/or will not hold its return to zero. Sometimes these problems appear weeks after the actual lightning strike!

It is obvious that a high level of protection against lightning strikes can only be established if the complete system is protected. The decision to protect a system or part of a system should be based on: the location (urban area or open field), the average ground flash density (ask for statistics at the appropriate

Load Cell Technology

institute), the costs incurred during a breakdown period, the expenses for the replacement of parts and workmanship, and the insurance company requirements (or premiums!).

Protection can be considered in two stages; external and internal.

2.4.1 External protection

External protection entails bonding the steel roof of the cabin where the indicator is located or any nearby structure or a high protection mast in such a matter as to provide a preferential point of discharge and safely conduct the surge to earth via conductors.

In fact considerable controversy surrounds such external protection. A weighbridge or in general a scale is not an attractive point for lightning to strike, but a 60 ft mast has an attractive radius of 240 ft. Lightning which might otherwise have struck a building or tree 180 ft or more away will now be captured to produce a current surge to ground within the very neighborhood of the weighbridge!

Unless very stringent precautions are taken such a surge will produce an electromagnetic induced pulse which will undoubtedly cause severe damage to the weighbridge.

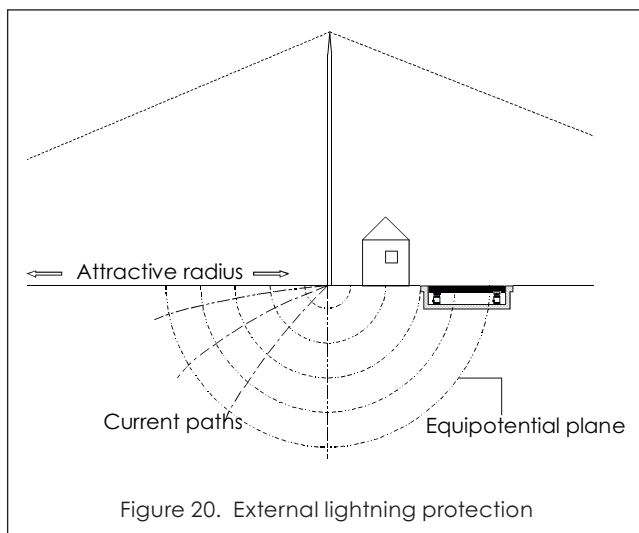

Figure 20. External lightning protection

2.4.2 Internal protection

Internal lightning protection sets out to provide potential equalization throughout the whole system by defining a central point about which all the electrical systems can float or by using Surge Protection Devices (SPDs).

Surge protection devices are designed to control line-line and line-earth voltages to levels acceptable to the equipment. An SPD incorporates combinations of gas-filled discharge tubes for high current surge diversion and zener diodes for secure voltage clamping with minimal leakage. For AC power applications, varistors are often used because of their higher power absorption capability. Most SPDs are connected in series, similar to shunt diode barriers for intrinsically safe systems.

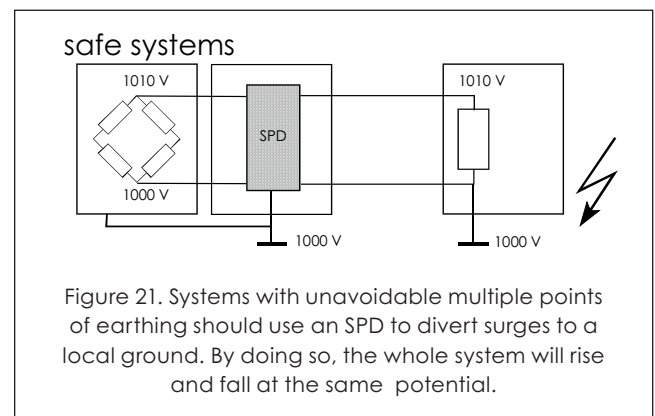

Figure 21. Systems with unavoidable multiple points of earthing should use an SPD to divert surges to a local ground. By doing so, the whole system will rise and fall at the same potential.

Any device which works by diverting large currents to a local ground must have a low impedance connection to that ground. This means that the bonding connection must be of low resistance (well below 0.5Ω), short in length and as direct as possible without sharp bends. Verify the earth connections at least twice a year and coat all connections with a good antioxidant grease.

Any external connection such as AC power lines, communication ports and the signal/excitation cable is a potential source of surges or transients. Central to

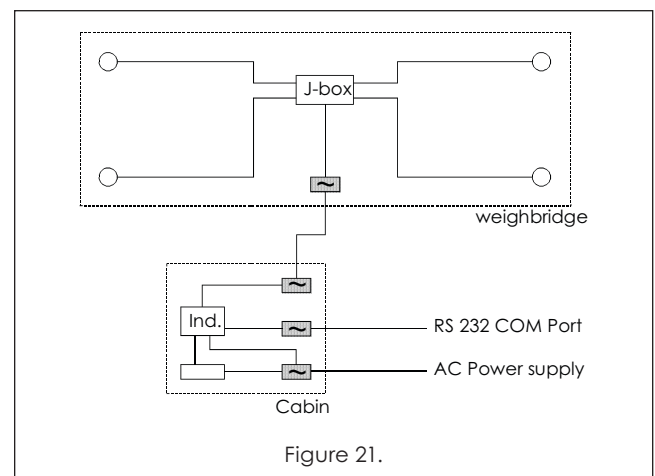

Figure 21.

Load Cell Technology

the provision of lightning protection is therefore the installation of an SPD at all external connections:

3. Maintenance

Maintenance is often overlooked or ignored by both load cell users and service companies. However, the regular service and maintenance of load cells in a weighing system will greatly improve their long-term reliability and performance as well as greatly reduce their sensitivity to corrosion. Maintenance inspections can be divided into two categories:

Routine:

Performed at periodic intervals, it includes the removal of any material or debris buildup from around the load cells and mounting fixtures. Serious damage can occur to the load cells if mounting systems do not function correctly. Any damage or degradation of surface coatings should be remedied and all cables and junction-boxes should be checked. To minimize the effects of flooding, any drainage systems in the pit should be free from debris. Where required, regular wash down of the load cell should be carried out to prevent chemical attack.

Ad hoc:

Made immediately after any adverse or unexpected events such as flash floods, gales, seismic activity or electrical storms.

In general, careful consideration must be given to any reason for failure. If this has occurred as a result of ingress of water or chemicals, then continued deterioration of any other load cell(s) in the system can be expected, resulting in mechanical failure. This failure can have serious safety and cost consequences. Always remove the load cell with care and attach a label with comments to the problem or mode of failure. Never cut the cable at the gland to facilitate removal; load cells cannot be tested by us without cables!

DOs and DON'Ts of Load Cells – Summary

Load Cell Selection and Design

- Do select the right load cell for the application in terms of type and environmental compatibility.
- Do choose the right capacity.
- Do consider the required accuracy class.
- Do consider all environmental aspects before

making the final choice (whether they are always or occasionally present at the place(s) the load cells will operate).

- Do provide for any additional environmental protection at the design stage.
- Do design-in adequate over/under load protection as well as protection from other mechanical damage (e.g., physical abuse, rodent problems).
- Don't make the choice based only on price — cost of ownership is more important.
- Don't allow load cells to operate above their rated capacity.
- Don't over specify — look at overall system limitations on accuracy (e.g., mechanical pipe work, vibration, etc.).
- Don't ignore that hurricane or flood that comes once every 2 or 3 years.
- Don't build in water/debris traps.
- Don't assume "it" will never happen, and never use the load cell as a mechanical fuse.
- Don't forget to provide adequate protection for the load cell cable, near the load cell if possible.

Installation And Fitting

- Do use dummy load cells prior to installation.
- Do store and handle load cells carefully prior to and during installation, and try to keep copies of the Certificate of Calibration in a safe place. Check load cells before fitting for correct model, capacity, thread combination, etc.
- Do check that any threaded fittings screw smoothly into the load cell before final assembly.
- Do use high quality bolts with the recommended torque.
- Do check that adequate and accurately fitted mounting surfaces are provided.
- Do use care when tightening mounting bolts and restraints such as tie-bars.
- Do use lock nuts appropriate on threaded fittings, especially if vibration is present.
- Do check cable color code for load cell prior to connection — VPG Transducers has two basic color codes.
- Do use good quality connecting terminals/junction boxes. Solder joints if possible.
- Don't carry out electric welding near load cells if possible.
- Don't forget to check specific storage and operating temperature ranges for the load cells.

Load Cell Technology

- Don't ever carry load cells by their cables!
- Don't force bolts or other threaded assemblies.
- Don't use mounting bolts to pull uneven surfaces together — use shims as appropriate.
- Don't use excessive force when fitting/tightening mounting bolts or hardware, especially on low capacity cells.
- Don't twist "S" cells when tightening threaded fittings.
- Don't cut load cell cables unless necessary, performance may be effected.
- Don't allow moisture to get at any interconnections.
- Don't allow load cell to be the electrical link between ground and metal weigh structure.

Maintenance

- Do regularly inspect load cells and weigh system especially after extreme weather conditions (electrical storms, flooding, seismic activity, etc.) and also before and after the seasons.
- Do check for corrosion damage to the load cell and mounting hardware. If practical, carry out

cleaning and any remedial work (paint or other protective coating) before it is too late.

- Do give special care and attention to critical areas of the load cell such as metal bellows, seals, etc. Those features are important in the operation and performance of the product.
- Don't allow build up of debris around load cell or mounts.
- Don't allow any drains to become blocked with leaves or other debris.
- Don't disconnect and just re-calibrate one or more load cells in a system if they cease to function. Mechanical failure may have catastrophic effects.

Finally

- Do remove load cell with care and attach a label with comments relating to the problem or mode of failure.
- Do return a copy of the Certificate of Calibration with the load cell if available.
- Don't cut cable at the gland to facilitate removal, please! We cannot test load cells without cables!